

 **Leybold**

# **SCROLLVAC** plus

## Defining Vacuum



# The SCROLLVAC plus

No oil contamination and higher robustness due to hermetic sealing of rotating parts from pumping chamber

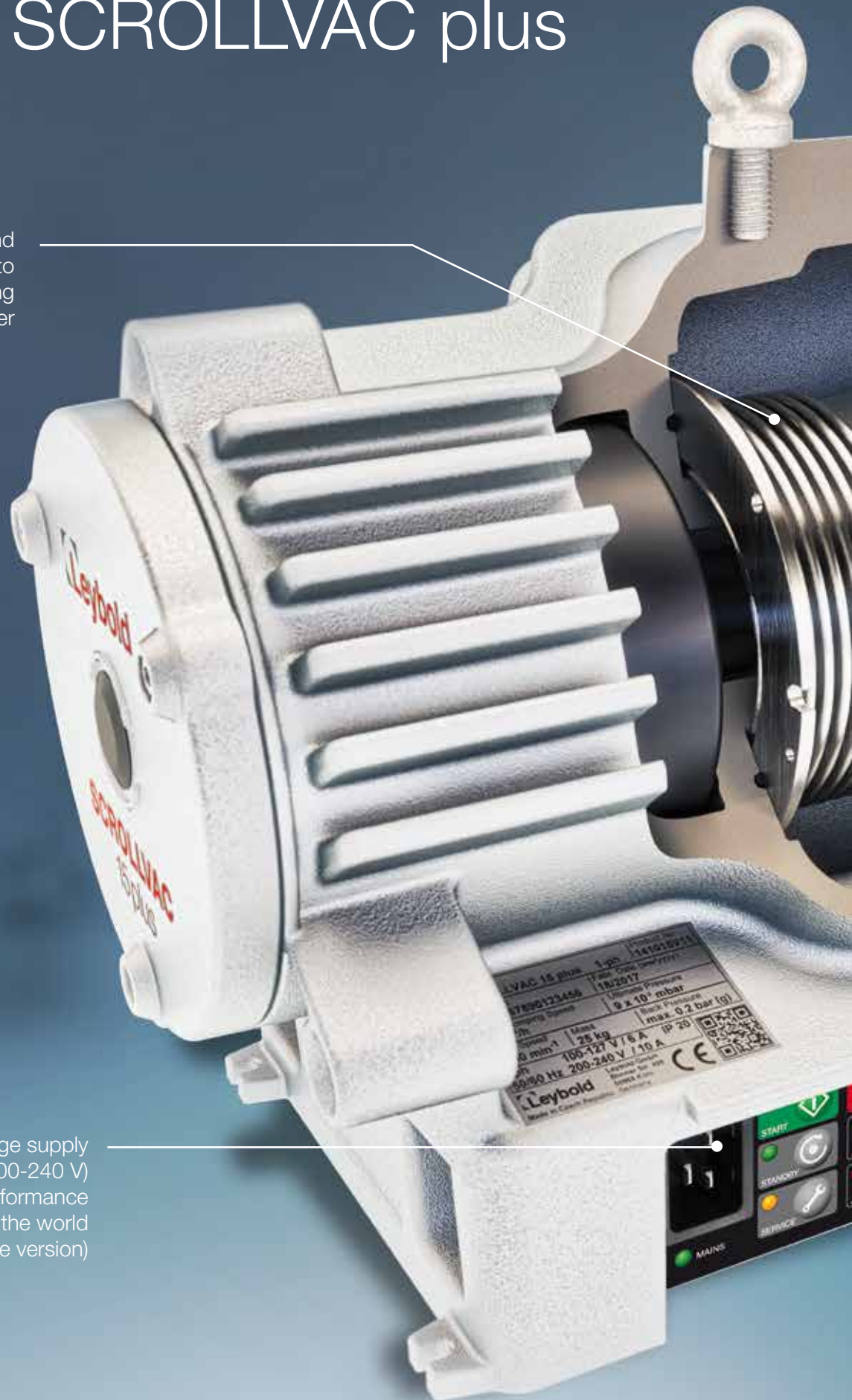

Universal voltage supply (100-127 V, 200-240 V) for constant performance everywhere in the world (single-phase version)



DN 25 ISO-KF Inlet

Gas ballast switch  
(option: can be blanked off  
or exchanged by purge gas  
connector)

Quiet air cooling

DN 25 ISO-KF exhaust  
with integrated suckback valve



Control panel for convenient access  
to pump functions with integrated  
hours counter and remote control  
interface (single-phase version)

3-phase model available (without integrated  
frequency converter)





# Defining Vacuum –

The SCROLLVAC plus range of dry vacuum pumps provides a flexible, robust and simple solution across a wide spectrum of applications. SCROLLVAC plus demonstrates what is possible from a dry scroll pump.



Able to address the widest range of applications ...

## Flexible.

We understand flexibility and choice is essential when selecting the right dry vacuum solution for your application. With single-phase and three-phase variants and versions for specialized applications, you can be sure to find a member of the SCROLLVAC plus family perfect for you.

- Pump versions in the range covering pumping speeds of 7, 10, 15 and 18 m<sup>3</sup>/h
- Single-phase variant feature universal voltage drive for constant performance world-wide
- Three-phase electronic-free variants for radiation and high magnetic field applications
- Integrated gas ballast permits pumping of condensable vapors
- Compact and lightweight design permits simple integration into your new or existing vacuum system

Ready to withstand and overcome demanding conditions ...

## Robust.

SCROLLVAC plus is built to maintain performance and reliability in the most demanding applications. With the bearings completely separated from the pumping mechanism, you are assured of zero contamination within the vacuum envelope along with exceptional vapor handling.

- Truly dry vacuum pump with pump bearings isolated from the vacuum space eliminating any risk of contamination
- No shaft seal to wear and hence longer service intervals and improved leak tightness
- The ideal dry pump solution for backing turbomolecular and cryo pumps
- Optional C variant may be used for some applications involving the pumping of aggressive media and chemicals

# SCROLLVAC plus, the dry scroll pump



## The pumping principle

A Scroll pump consists of two engaged spiral forms. One scroll form is mounted eccentrically to the other and is made to move in an orbiting path relative to the fixed scroll. This creates crescent shaped volumes that are driven from the outside to the inside of the forms thereby pumping the gas.

Easy to understand and uncomplicated ...

### Simple.

Not only the service and tip seal change is easy and quick, the long service intervals mean that SCROLLVAC plus can become the “fit and forget” solution.

- Latest in tip seal technology giving significantly longer periods between tip seal changes, typically 2.5 years, to maximize up-time and productivity
- Easy maintenance with a typical tip-seal change in under 10 minutes by yourself
- Running time hours-counter included as standard

Economize by switching to the latest technology ...

### Environment.

Think the environment is too big for you to make an impact? We are always looking at how we can reduce the impact on the environment, and selecting the SCROLLVAC plus can make an immediate improvement on your local workspace.

- No contaminated waste oil to dispose of, eliminating the need for costly disposal and used oil recycling
- Low noise at < 55 dB(A) for a quiet work/laboratory environment
- Reduced power consumption compared to other pumping mechanisms

# p from Leybold.



Reliable products and application expertise ...  
the Leybold guarantee at any time!

## Universal.

Designed to perform across a wide spectrum of applications, from general laboratory, light industrial and research through to the more aggressive of chemical applications, SCROLLVAC plus makes selecting the right dry vacuum pump easy.

### Physical Research

- Dry-compression pump – zero risk of system contamination
- Excellent ultimate pressure for turbomolecular pumps
- High water vapor capacity for cryo-pump regeneration
- Low noise for a quiet working environment
- Electronic-free 3-phase pump for areas with radiation
- Long maintenance intervals and simple end-user serviceable

### Industry

- Robust pump with high vapor capacity for industrial applications including vacuum ovens, degassing, sterilization. Also suitable for cyclic duties
- No exposed bearings and no shaft seals, therefore reliable operation in numerous industrial applications
- Wide range of pumping performance options for all requirements

### Wet Chemistry

- Quiet and reliable operation for use in biological and wet chemistry laboratories
- High water vapor capacity for applications such as gel drying, centrifugal concentrators, rotary evaporators and solvent recovery
- Hermetic separation of pumping chamber and rotating parts, therefore no reaction of pumped gases with lubricant
- C versions available for more aggressive gases

### Gas Recovery

- High leak tightness assures no gas contamination or loss in gas recovery applications
- Excellent Helium pumping performance

## Dimensions

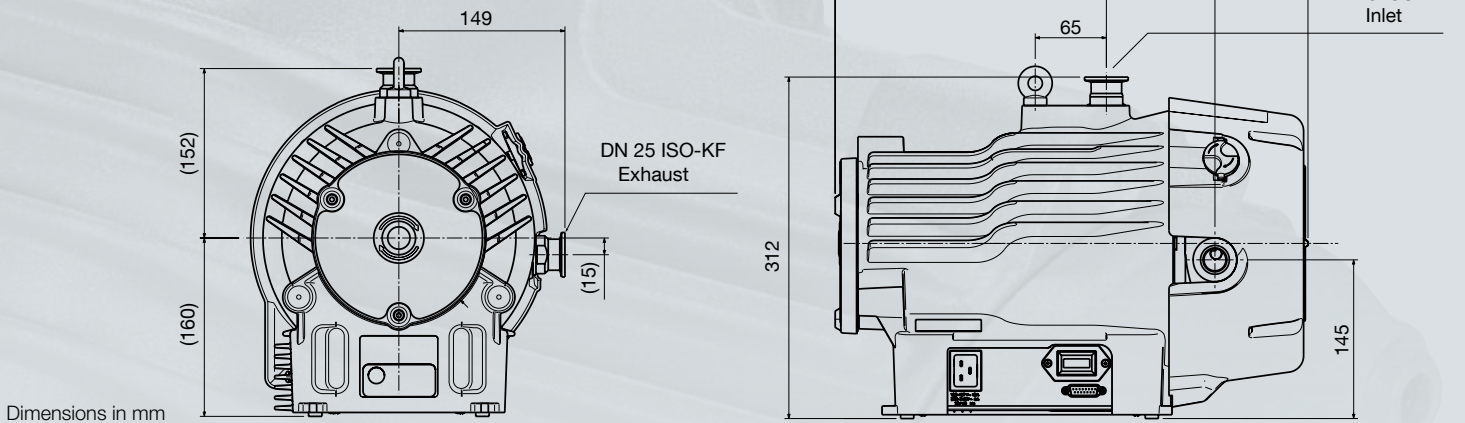

C versions are ready to withstand harsh conditions.

### SCROLLVAC C plus

SCROLLVAC C plus variant has been designed for more aggressive applications, where potential deterioration of the internal parts due to corrosion needs to be considered. In combination with suitable purge gas flows, this means that SCROLLVAC C plus models can be configured to handle corrosive solvents and chemicals:

- Chemical resistant exhaust check valve and gas ballast valve
- Stainless steel inlet and exhaust flanges
- Conversion kits are available allowing customers to upgrade their standard variants

Contact us for advice

## Performance

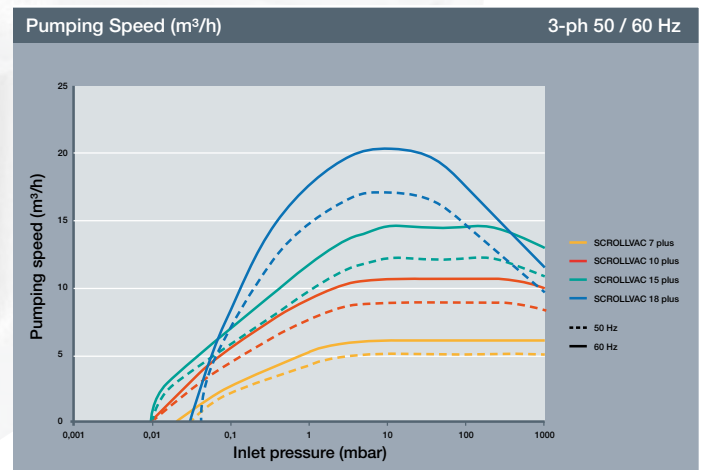
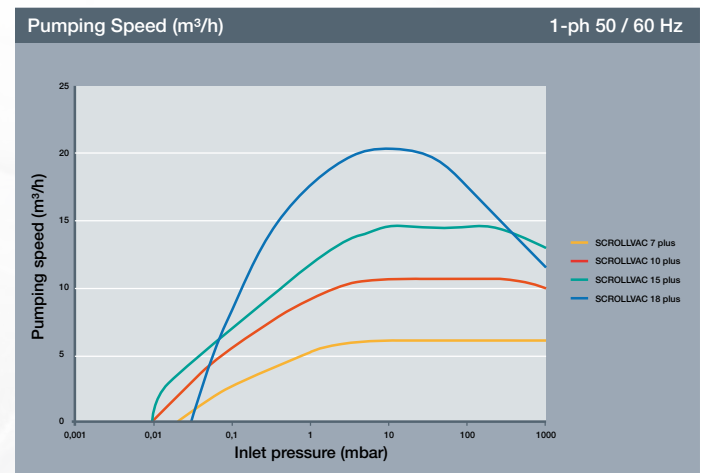

# Technical Data

## Ordering information

SCROLLVAC		7 plus	10 plus	15 plus	18 plus
Max. pumping speed	m <sup>3</sup> /h	6.1	10.6	14.5	20.0
Ultimate pressure with closed gas ballast	mbar	0.02	0.009	0.009	0.03
Water vapor capacity with gas ballast	g/h	100	140	280	220
Mains voltage	single phase motor	V			
	three-phase motor	V			
		100-127, 200-240 (± 10%), 50/60 Hz			
		200/380-415 50 Hz, 200-230/460 60 Hz			
Power consumption at ultimate pressure	W	260	280	300	260
Mains connector	single phase motor	IEC EN60320 C19			
Noise level	dB(A)	< 55			
Inlet flange / Exhaust flange		DN 25 ISO-KF / DN 25 ISO-KF			
Weight	kg	26	25	26	25
Dimensions (W x H x D)	mm	432 x 312 x 298			

### Ordering information\*

SCROLLVAC	7 plus	10 plus	15 plus	18 plus
<b>Scroll vacuum pump, with single phase motor</b>				
Standard version, with gas ballast	<b>141007V10</b>	<b>141010V10</b>	<b>141015V10</b>	<b>141018V10</b>
C version for aggressive applications, with gas ballast	-	-	<b>141015V12</b>	<b>141018V12</b>
<b>Scroll vacuum pump, with 3-phase motor</b>				
Standard version, with gas ballast	-	<b>141010V30</b>	<b>141015V30</b>	<b>141018V30</b>
C version for aggressive applications, with gas ballast	-	<b>141010V32</b>	<b>141015V32</b>	<b>141018V32</b>
<b>Mains cables</b> (mandatory, required for operation)				
EU - CEE 7/7 (Schuko) - IEC-60320 C19, 2.0 m length			<b>161 810 EU</b>	
UK - BS 1363 - IEC-60320 C19, 2.0 m length			<b>161 810 UK</b>	
USA (115 V) - NEMA 5-15P - IEC-60320 C19, 2 m length			<b>141 103 US</b>	
USA (230 V) - NEMA 6-15P - IEC-60320 C19, 2.5 m length			<b>161 810 US</b>	
<b>Accessories</b>				
Gas ballast adapter blank			<b>141100A01</b>	
Purge gas adapter for external gas line				
with fine restriction (quick connect 1/4")			<b>141100A03</b>	
no restriction (quick connect 1/4")			<b>141100A02</b>	
Chemical resistance conversion kit (C-conversion KIT)	<b>141101A01</b>	<b>141101A01</b>	<b>141101A01</b>	<b>141101A02</b>
Vibration isolators			<b>141102A01</b>	
SC plus exhaust silencer			<b>141102A02</b>	

\* Selection from the product range. Further model versions or accessories on request. Visit our webshop [www.leyboldproducts.com](http://www.leyboldproducts.com)

**Contact us for more technical details on the entire SCROLLVAC plus series.**

### ATEX certified

All SCROLLVAC plus dry pumps are ATEX certified to meet the requirements of group II category 3 equipment: ATEX II 3 G c IIB T4 internal



**Pioneering products. Passionately applied.**